

Hack10 Clevis Clutch

The Hack10 clevis clutch is specifically designed as a chain shortening device for use in Hackett grade 10 chain sling assemblies. Featuring a clevis attachment type, this component connects to master links and sub assemblies via a connector and a short length of chain. This configuration offers greater flexibility than other chain shortening devices. Manufactured from alloy steel, the Hack10 clevis clutch is 25% stronger than a grade 8 equivalent, delivering a greater working load limit without the need for a larger diameter chain sling.

Standards: designed and manufactured in accordance with EN1677-1, ASTM A952/A952M, and DIN PAS 1061 and suitable for use in chain slings certified to EN818-4.

Product sizes: available for chain sizes from 8mm to 16mm and with working load limits from 2.5 tonnes to 10.0 tonnes.

Temperature: operational temperature range of - 40°C to + 200°C without reduction in working load limit.

Material: alloy steel.

Testing: crack detection following heat treatment, and proof load tested to 2.5 times working load limit.

Safety factor: 4 : 1.

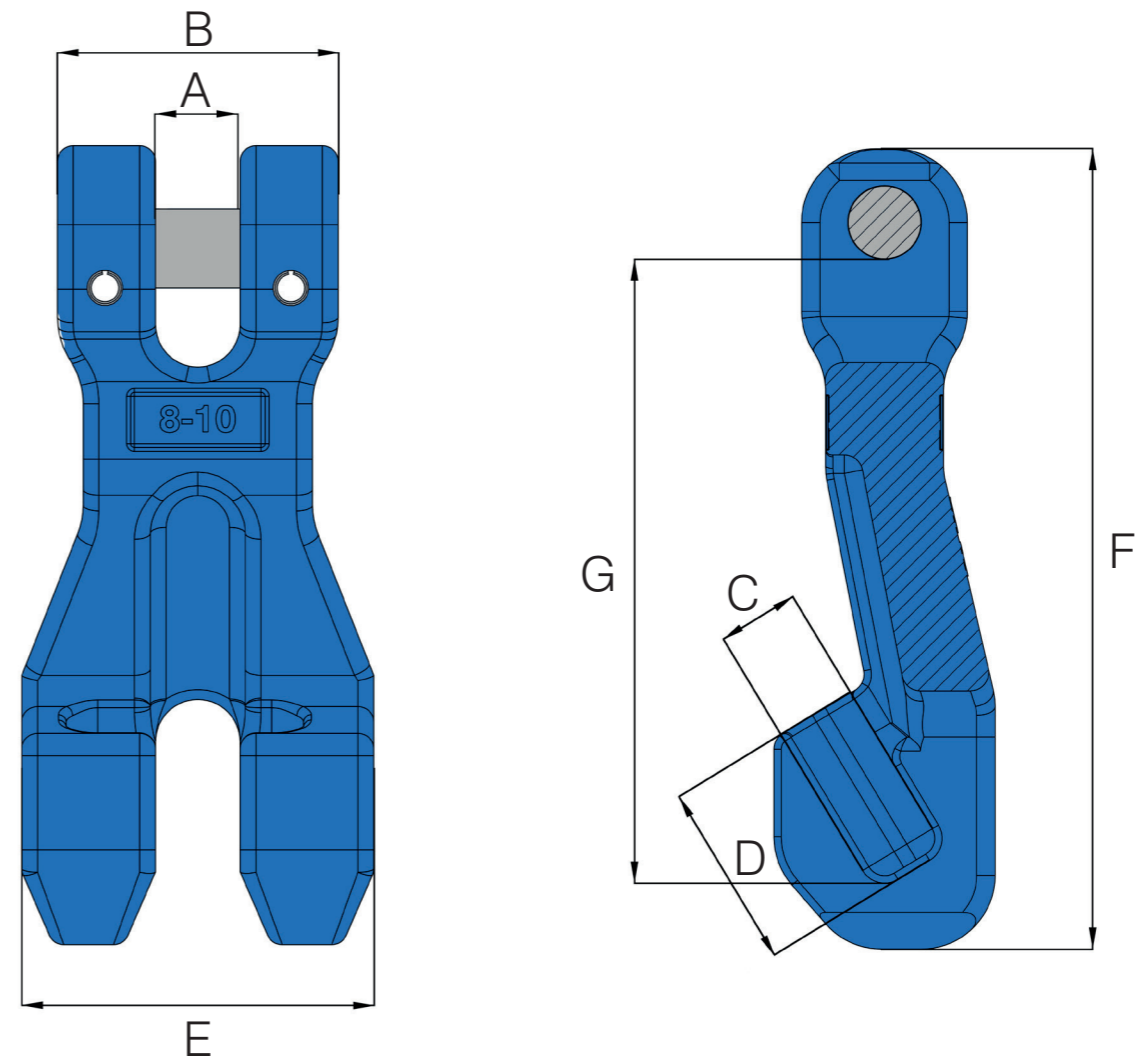

Specifications

Part Code	Chain Size mm	A mm	B mm	C mm	D mm	E mm	F mm	G mm	Box Qty.	WLL tonnes	Mass kg
10-H10-08	8	9.5	36.0	10.5	17.0	45.0	101.0	70.0	50	2.5	0.37
10-H10-10	10	13.0	48.0	12.4	28.0	55.0	138.0	101.5	21	4.0	0.97
10-H10-13	13	16.5	59.0	16.0	34.5	75.0	177.0	115.0	10	6.7	2.01
10-H10-16	16	18.5	70.0	19.5	40.0	93.0	220.0	150.5	6	10.0	3.32

Hack10 Clevis Clutch

The Hack10 clevis clutch is specifically designed as a chain shortening device for use in Hackett grade 10 chain sling assemblies. Featuring a clevis attachment type, this component connects to master links and sub assemblies via a connector and a short length of chain. This configuration offers greater flexibility than other chain shortening devices. Manufactured from alloy steel, the Hack10 clevis clutch is 25% stronger than a grade 8 equivalent, delivering a greater working load limit without the need for a larger diameter chain sling.

Standards: designed and manufactured in accordance with EN1677-1, ASTM A952/A952M, and DIN PAS 1061 and suitable for use in chain slings certified to EN818-4.

Product sizes: available for chain sizes from 5/16 inch to 5/8 inch and with working load limits from 5,700 lbs to 22,600 lbs.

Temperature: operational temperature range of - 40°C to + 200°C without reduction in working load limit.

Material: alloy steel.

Testing: crack detection following heat treatment, and proof load tested to 2.5 times working load limit.

Safety factor: 4 : 1.

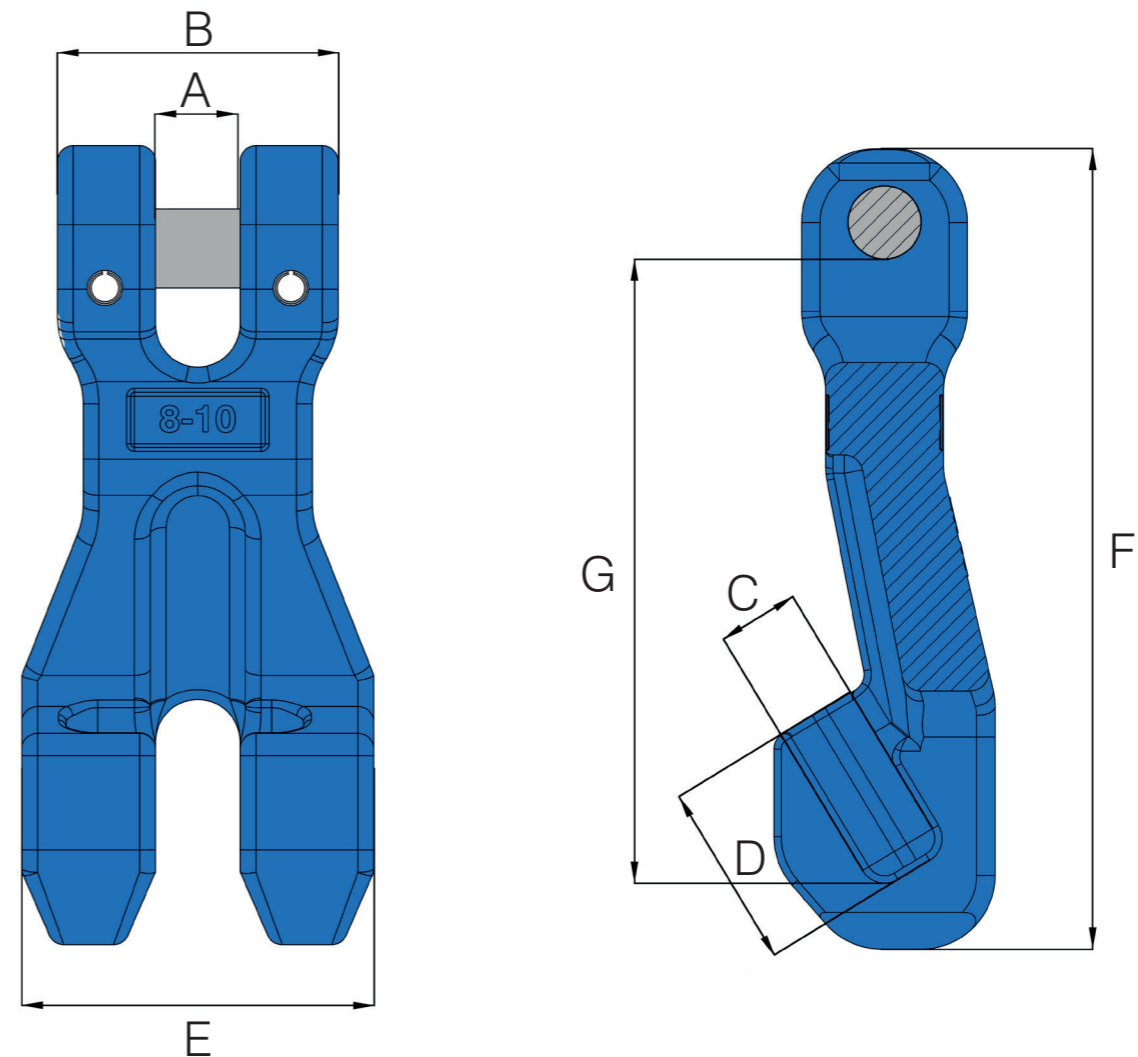

Specifications

Part Code	Chain Size inch	A inch	B inch	C inch	D inch	E inch	F inch	G inch	Box Qty.	WLL lbs	Mass lbs
10-H10-08	5/16	0.37	1.42	0.41	0.67	1.77	3.98	2.76	50	5700	0.82
10-H10-10	3/8	0.51	1.89	0.49	1.10	2.17	5.43	4.00	21	8800	2.14
10-H10-13	1/2	0.65	2.32	0.63	1.36	2.95	6.97	4.53	10	15000	4.43
10-H10-16	5/8	0.73	2.76	0.77	1.57	3.66	8.66	5.93	6	22600	7.32